



Continuous production of fatty acid ethyl esters from soybean oil at supercritical conditions

Camila da Silva^{1,2*}, Gustavo Borges³, Fernanda de Castilhos⁴, José Vladimir Oliveira³ and Lúcio Cardozo Filho²

¹Departamento de Tecnologia, Universidade Estadual de Maringá, Umuarama, Paraná, Brazil. ²Departamento de Engenharia Química, Universidade Estadual de Maringá, Av. Colombo, 5790, 87020-900, Maringá, Paraná, Brazil. ³Departamento de Engenharia de Alimentos, Universidade Regional Integrada, Erechim, Rio Grande do Sul, Brazil. ⁴Departamento de Engenharia Química, Universidade Federal do Paraná, Curitiba, Paraná, Brazil. *Author for correspondence. E-mail: camiladasilva.eq@gmail.com

ABSTRACT. This work reports the production of fatty acid ethyl esters (FAEE) from the transesterification of soybean oil in supercritical ethanol in a continuous catalyst-free process using different reactor configurations. Experiments were performed in a tubular reactor in one-step reaction and experimentally simulating two reactors, one operated in series and the other a recycle reactor. The reaction products were analyzed for their content of residual triglycerides, glycerol, monoglycerides, diglycerides, ethyl esters and decomposition. Results show that the configurations studied with intermediate separation of glycerol afford higher conversions of vegetable oil to their fatty acid ethyl esters derivatives when compared to the one-step reaction, with relatively low decomposition of fatty acids (< 5.0 wt%).

Keywords: supercritical method, biodiesel, continuous process, non-catalytic transesterification.

Produção contínua de ésteres etílicos de ácidos graxos do óleo de soja em condições supercríticas

RESUMO. Este trabalho reporta a produção de ésteres etílicos de ácidos graxos a partir da transesterificação de óleo de soja em etanol supercrítico em um processo contínuo e não-catalítico utilizando diferentes configurações de reatores. Os experimentos foram realizados com a utilização um reator tubular em uma etapa reacional e com a simulação experimental de dois reatores operando em série um reator com reciclo. Os produtos das reações foram analisados em relação ao teor de triglicérides, glicerol, monoglicérides, diglicérides, ésteres etílicos e decomposição. Os resultados obtidos mostram que as configurações estudadas com remoção intermediária de glicerol apresentaram elevadas conversões do óleo vegetal em seus respectivos ésteres etílicos, quando comparados ao processo em uma etapa reacional, com baixa decomposição de ácidos graxos (< 5,0%).

Palavras-chave: método supercrítico, biodiesel, processo contínuo, transesterificação não catalítica.

Introduction

The transesterification of vegetal oils using an alcohol at supercritical conditions comprises a method used to produce biodiesel and has gained growing interest due to the benefits related to the environment and quality of the fuel generated (DEMIRBAS, 2002; KUSDIANA; SAKA, 2001; MADRAS et al., 2004; PINNARAT; SAVAGE, 2008; WEN et al., 2009). According to the current literature, catalyst-free alcoholysis reactions at high temperature and pressure conditions provide improved phase solubility, decrease mass-transfer limitations, afford higher reaction rates and make the separation and purification steps of the products easier. Additionally, it has been shown that the so-called supercritical method is more tolerant to the

presence of water (KUSDIANA; SAKA, 2004a; VIEITEZ et al., 2008) and free fatty acids than the conventional alkali-catalyzed technique, and hence more tolerant to various types of vegetable oils, even fried and waste oils (KUSDIANA; SAKA, 2004a; RATHORE; MADRAS, 2007).

However, the supercritical method requires high molar ratios of alcohol to oil and the use of high temperatures and pressures to achieve satisfactory conversion levels, leading to high processing costs and in many cases causing degradation of the fatty acid esters formed (IMAHARA et al., 2008) and secondary reactions with the glycerol formed as by-product (AIMARETTI et al., 2009), hence decreasing the reaction conversion (HE et al., 2007; KUSDIANA; SAKA, 2004b; MINAMI; SAKA, 2006; SILVA et al., 2007; VIEITEZ et al., 2009).

Attempts to reduce the expected high operating cost and product degradation have been made through the addition of co-solvents (CAO et al., 2005; HAN et al., 2005; ANITESCU et al., 2008; BERTOLDI et al., 2009), two-step or recycle process with removal of glycerol generated in the first step (BUSTO et al., 2006; D'IPPOLITO et al., 2007) and adopting a two-step process comprising hydrolysis of triglycerides in subcritical water with subsequent esterification of fatty acids (KUSDIANA; SAKA, 2004b; MINAMI; SAKA, 2006).

The reaction conducted in two steps with reactors in series and/or recycling the outgoing stream with intermediate removal of glycerol can increase the yield of the reaction, since the reaction may take place at lower alcohol-to-oil ratios, increasing the reaction rates of biodiesel production (CRAWFORD et al., 2007). The reaction of glycerol formed during the process with other components of the reaction medium may lead to a decrease in esters yield (MINAMI; SAKA, 2006) and undesirable consumption of alcohol (AIMARETTI et al., 2009).

In this context, the main objective of this work is to investigate the continuous transesterification of soybean oil under supercritical ethanol conditions, in a one-step reaction and experimentally simulating of two operation modes, reactors in series and a recycle reactor.

Material and methods

Materials

Commercial refined soybean oil (Soya, Bunge Alimentos S/A - Brazil) and ethanol (Merck, 99.9%) were used as substrates without further treatment. Other solvents, standards and reagents used in the derivatization step required for the analysis were supplied by Sigma-Aldrich. Chemical composition for the soybean oil used in this work is reported elsewhere (VIEITEZ et al., 2008). The acid value (mg KOH g^{-1}) and water content (wt%, Karl Fischer titration method, DL 50, Mettler-Toledo) was determined to be approximately 0.2 and 0.04, respectively.

Apparatus and experimental procedure

The experimental reaction system used in this work, schematically presented in Figure 1, is similar to that used previously by Bertoldi et al. (2009) and Silva et al. (2010). The substrates, ethanol and oil, at the pre-established molar ratio,

were placed in a closed Erlenmeyer and mixed using a mechanical stirring device, then fed into the reaction system by a high-pressure liquid pump (Acuflo). The reactor, which has a capacity of 88 mL and is made of stainless steel tubing (316 L 6.35 mm OD and 3.2 mm inner diameter, HIP tubing), was placed in a furnace with controlled temperature and monitored by two thermocouples directly connected at the inlet and outlet of the reactor. With this arrangement, the reaction temperature was controlled with a precision of ± 5 K. The system pressure was controlled by a control loop consisting of a pressure transducer (Smar, model A5), a PID controller (Novus, Model N1100) and a pneumatic valve (BaumannTM, model 51000). Though more complex definitions could be used for the evaluation of the time spent in the reactor (the superficial residence time) (MINAMI; SAKA, 2006; SILVA et al., 2007), in this work the residence time was computed dividing the volume of the reactor (mL) by the flow rate of substrates (mL min^{-1}) set in the liquid pump, a true, engineering parameter.

A significant sample of the first step was collected at the reactor outlet after reaching the steady state condition (named model reaction), i.e., after a reactor space-time had been elapsed at least three times. Afterwards, evaporation of ethanol was performed in the sample collected at 348 K and 13.7 kPa of vacuum and separation of the glycerol formed by centrifugation at 3000 rpm for 10 min. In the simulated experiments of reactors in series or recycle reactor, ethanol was added to the resulting output stream (free of ethanol and glycerol) to again reach an oil-to-ethanol mass ratio of 1:1. For the process with recycle, two mass ratios, on the basis of oil-to-ethanol feed stream, 20 and 40 wt%, were adopted for a second (R_1) and a third (R_2) pass through the reactor. As in the first pass (model reaction), for the recycle reactor, ethanol was evaporated and glycerol generated was separated from R_1 , always keeping fixed temperature at 598 K, 20 MPa and oil-to-ethanol mass ratio of 1:1. Preliminary tests were carried out for some experimental conditions, affording excellent reproducibility of the experimental apparatus (SILVA et al., 2010). Based on duplicate experiments, the overall experimental error was found to be less than 5 wt% on FAEE content.

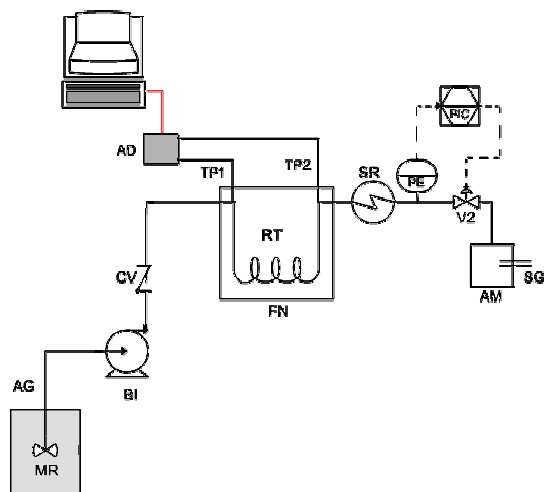

Figure 1. Schematic diagram of the experimental apparatus. RM - reaction mixture; MS - mechanical stirring device; LP - high-pressure liquid pump; CV - check-valve; F - furnace; TR - tubular reactor; T1 - temperature indicator at the reactor inlet; T2 - temperature indicator at the reactor outlet; DA - data acquisition system; CS - cooling system; PI - pressure indicator; PIC - controller - V - pressure control valve; S - glass collector.

Material e methods

Analysis of Fatty Acid Ethyl Esters (FAEE)

Samples were first submitted to ethanol evaporation until constant weight in a vacuum oven (338 K, 0.05 MPa) and then diluted with 2 mL of ethanol and 8 mL of n-heptane. Afterwards, a small amount was transferred to a 1 mL flask in order to obtain a concentration of 1000 ppm and then the internal standard was added at a concentration of 250 ppm using n-heptane as solvent. After that, 1 μ L of solution was injected in triplicate in a gas chromatograph (Shimadzu GC-2010), equipped with FID, autoinjector AOC-20i and a capillary column (DBWAX, 30 m x 0.25 mm x 0.25 μ m). Column temperature was programmed from 393 K, holding 2 min., heating to 453 K at 10 K min.⁻¹, holding 3 min., and to 503 K at 5 K min.⁻¹, holding 2 min. Helium was used as carrier gas, and the injection and detector temperatures were 523 K with 1:50 split ratio. Compounds were quantified upon analysis following the Standard UNE-EN 14103 (2003), and the reaction conversion was then calculated based on the content of ethyl esters in the analyzed sample and on the reaction stoichiometry.

Decomposition of fatty acids

Samples were treated with BF₃/MeOH as described by Method AOCS Ce 2-66 (1990) in order to derivatize all the fatty acids (mono-, di- and triglycerides, free fatty acids and also ethyl esters) to the

corresponding methyl esters, and then analyzed by GC as described above. Decomposition percentage was calculated as described by Vicitez et al. (2008), Vicitez et al. (2009) and Bertoldi et al. (2009).

Analysis of mono-, di-, triglycerides (MG, DG and TG) and glycerol

Mono-, di- and triglycerides of soybean and glycerol were quantified upon analysis following the Standard UNE-EN 14105 (2003). Samples prepared as described above were treated with MSTFA (N-methyl-N-(trimethylsilyl) trifluoroacetamide)/pyridine to ensure derivatization of free alcohols to their corresponding trimethylsilyl esters and transferred to a 10 mL flask using n-heptane as solvent. GC analysis was conducted in the above-described equipment, with a column DB-5HT (30 m x 0.25 mm x 0.10 μ m) and on-column injector. The column temperature gradient was set as follows: 323 K, holding 1 min.; 288 K min.⁻¹ up to 453 K; 280 K min.⁻¹ up to 503 K; and 283 K min.⁻¹ up to 653 K, holding 8 min. The detector temperature was 653 K; pressure of carrier gas (hydrogen) was 80 kPa. Standard samples of 1 μ L were injected in triplicate.

Results and discussion

One step reaction

To evaluate the reaction of soybean oil at supercritical conditions in one step, experiments were performed at 598 K, oil-to-ethanol mass ratio of 1:1 and pressure of 10 and 20 MPa. Figure 2 shows the time course of the FAEE content and decomposition for these conditions. It can be seen from Figure 2 that an increase in pressure leads to a sharp enhancement of fatty acid ethyl esters (FAEE) and faster initial reaction rates. According to Figure 2, the best FAEE contents were obtained for 20 MPa, consistent with the results presented in the literature in the works of Kusdiana and Saka (2001) and Demirbas (2002) for transesterification reactions in batch mode, and Minami and Saka (2006), Silva et al. (2007) and Bertoldi et al. (2009) in continuous mode. At 598 K and 25 min. of residence time, 42 wt% of ethyl esters is obtained at 20 MPa and 22 wt% at 10 MPa. It was observed that as reaction time elapses, FAEE content decreases for reactions at 20 MPa, as observed in reports from the literature (BERTOLDI et al., 2009; MINAMI; SAKA, 2006; SILVA et al., 2007; VIEITEZ et al., 2009). High temperature values, typically above 573 K, cause decomposition reactions of esters formed

(DEMIRBAS, 2007; IMAHARA et al., 2008; KASIM et al., 2009; VIEITEZ et al., 2009) and can favor backward reaction of glycerol (AIMARETTI et al., 2009; ANITESCU et al., 2008) with products of reaction and may cause product degradation, thus decreasing the production of fatty acid esters.

Figure 2 shows the results regarding total decomposition of fatty acids determined by derivatization with BF_3/MetOH . It was observed that system pressure affects decomposition, at the higher residence time (about 45 min.), the decomposition of 4.9 wt% at 10 MPa increases to 7.5 wt% at 20 MPa. Pressures above 20 MPa were not considered in this work due to the low increase in FAEE content and the high initial investments (equipment costs) for the implementation of such process operated at higher pressures. It is believed that operational pressures above 20 MPa may not be industrially viable, increasing the implementation costs for biodiesel production through the supercritical transesterification method.

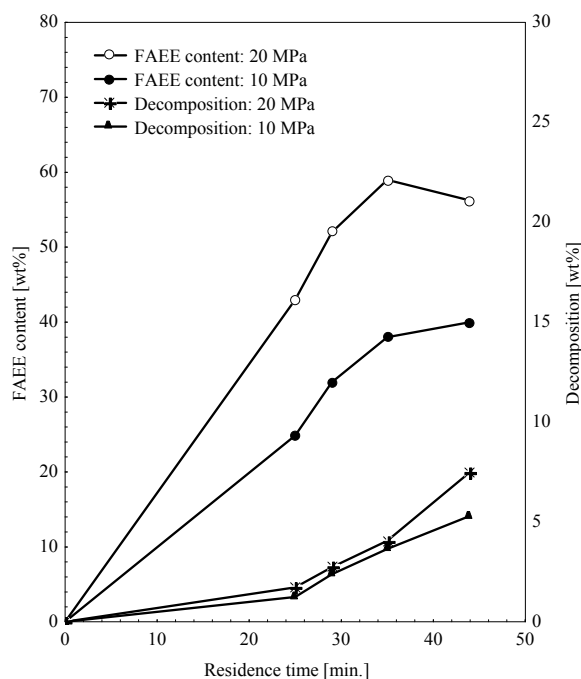

Figure 2. Effect of residence time and pressure on FAEE content and decomposition for reaction in one step operated at 598 K, oil-to-ethanol mass ratio of 1:1 and 20 MPa. Symbols are experimental data, and continuous lines are empirical draws just to improve visualization.

Two-step reaction

Model reaction

To evaluate the different configurations of reactors (series and recycle) using a tubular reactor,

an experimental condition was selected based on the results presented in the Figure 2: temperature of 598 K, pressure of 20 MPa and oil-to-ethanol mass ratio of 1:1, which led to about 52 wt% of fatty acid ethyl esters (FAEE) and decomposition of about 2.5 wt% for residence time of 30 min. In this sample the content of triglycerides (TG), diglycerides (DG), monoglycerides (MG) and glycerol was determined as about 9.9, 15.8, 12.7 and 5.1 wt%, respectively. A significant sample amount of the reaction was collected at this operating condition and stored for later study of reactor configurations. During sampling time, small samples were taken to assess the stability of reactor operation and the system remains in acceptable steady state condition with around 52 wt% of FAEE, as depicted in Figure 3.

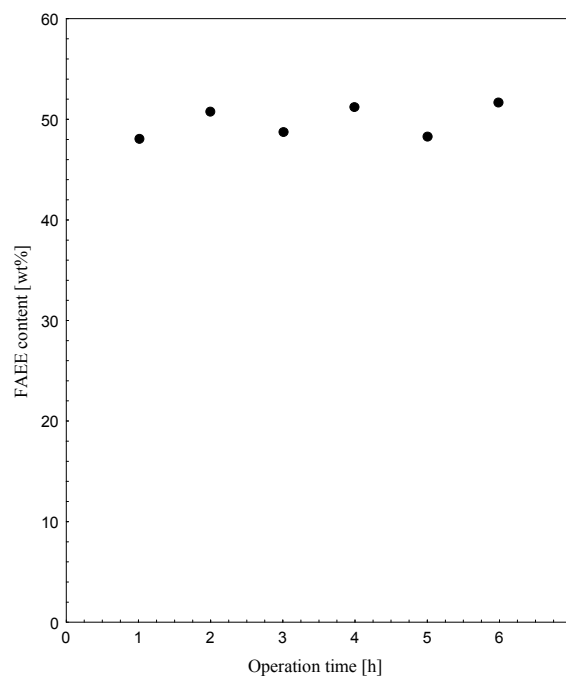

Figure 3. Reaction time-course in terms of FAEE content at 598 K, 20 MPa, oil-to-ethanol mass ratio of 1:1 in steady state condition.

Reactors in series

To conduct the reaction in series, ethanol was added to the sample obtained in the model reaction step (free of ethanol and glycerol) so as to give an oil-to-ethanol mass ratio of 1:1, just subtracting the FAEE content obtained, and then passed through the reactor at the temperature of 598 K, pressure of 20 MPa and for residence time of 20 and 30 min. (Figure 4). One can observe from Figure 4 that the content of FAEE significantly increased compared to the first reaction step (~ 52 wt%), resulting in

approximately 74 wt% for a residence time of 30 min. and low decomposition of FAEE (5.0wt%). Gui et al. (2009) reported ester yields of 72.7 wt% for the batch mode transesterification of palm oil in supercritical ethanol at 598 K using an oil-to-ethanol molar ratio of 1:38.75 and Tan et al. (2009) obtained 40 wt% of methyl esters yield at 633 K and oil to methanol molar ratio of 1:20 using a batch-type tube reactor for a residence time of 20 minutes. He et al. (2007) reported yields in the order of 75 wt% of methyl esters in the alcoholysis of soybean oil at supercritical conditions, 593 K, 32 MPa and oil:methanol molar ratio of 1:40. Wang et al. (2008) obtained in the continuous alcoholysis of soybean oil with methanol at oil:methanol molar ratio of 1:40, 15 MPa and 593 K, yields in the order of 70 wt% for conversion of soybean oil.

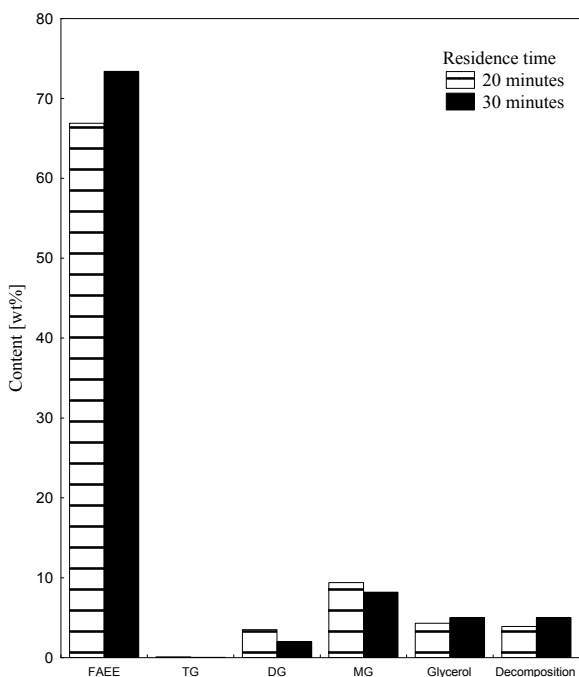

Figure 4. Effect of residence time on FAEE content and decomposition for a simulated reactor in series operated at 598 K, oil-to-ethanol mass ratio of 1:1 and 20 MPa.

Minami and Saka (2006) using a two-step process comprising hydrolysis of tryglicerides in subcritical water with subsequent esterification of fatty acids, reported a 90 wt% yield of methyl ester at 563 K, 20 MPa and water/TG of 1/1 ($v v^{-1}$) for the first step and methanol/fatty acid of 1.8/1 ($v v^{-1}$) in the second step, while 70 wt% of methyl esters yield was reported at 573 K, 20 MPa and methanol/TG of 1.8/1 ($v v^{-1}$) in 60 min. for a one-step process. Busto

et al. (2006) mentioned that to achieve high conversions in the second reaction step, high conversions are required in the first step, to allow proper miscibility of the mixture ester/alcohol/triglyceride. These authors reported conversions above 95 wt% using reactors operated in series operating at 523 K and oil-to-ethanol molar ratio of 1:10 for a residence time of 30 minutes, with a conversion in the first reaction step of 85 wt%, using methanol as substrate. The alcoholysis reaction in a supercritical two-step reaction was analyzed numerically by D'Ippolito et al. (2007), who argued that the first reaction step conducted by a CSTR followed a tubular reactor is the most suitable configuration.

For the results in terms of content of triglycerides (TG), diglycerides (DG), monoglycerides (MG) and glycerol shows in the Figure 4, where it can be noted that almost complete conversions of TG occurred for longer residence times (30 min.) with final lower percentage of DG and MG (2.0 and 8.2 wt%, respectively), consistent with the FAEE content values reported. Note also that glycerol content, formed as by-product, increases with increasing residence time, which agrees with increasing FAEE content.

Aimaretti et al. (2009) reported that the high decomposition rates observed in the supercritical alcoholysis of vegetable oils can be caused by secondary reactions of glycerol with other compounds of the reaction medium. Thus, the use of reactors in series, with intermediate separation of glycerol is justified, since low product decomposition values are observed at high residence times (5.0 wt%), which enables the achievement of higher yields at lower temperature (598 K) and relatively smaller amounts of alcohol (ethanol-to-oil mass ratio of 1:1 or 1:20 oil-to-ethanol molar ratio) when compared to the process operated in one step (BERTOLDI et al., 2009; HE et al., 2007; KUSDIANA; SAKA, 2004b; MINAMI; SAKA, 2006; SILVA et al., 2007; VIEITEZ et al., 2009).

Recycle reactor

To analyze the configuration of the recycle reactor, two different recycle ratios were studied: 20 and 40 wt% (on the basis of feeding, oil-to-ethanol, stream), at 598 K, residence time of 30 min., pressure at 20 MPa and oil-to-ethanol mass ratio of 1:1, with the first (model reaction) and second passes (R_1) free of ethanol and glycerol. Results for

these experimental simulations are shown in Figures 5 (a and b). It can be seen from Figure 5a that an increase in recycle ratio leads to a rise in FAEE content for R_1 , where 59 wt% were achieved and 67 wt% for recycling ratios of 20 and 40 wt%, respectively.

As cited by Busto et al. (2006), when operating with recycle, the non-reacted products, DG and MG and esters formed may act as co-solvents in the reaction medium, increasing the solubility between the phases and reducing the limitations of mass transfer, hence increasing the reaction conversion to FAEE. Granados et al. (2009) evaluated the addition of biodiesel (with a high FAEE content) in the batch reaction of sunflower oil at low pressure using CaO as catalyst and found that the presence of a small amount of biodiesel in the initial methanol-triglyceride mixture (3 wt% referred to oil) promoted a significant increase in triglyceride methanolysis.

Thus, as shown in Figure 5(b) for the step corresponding to recycle R_2 , which was formed with feeding stream and recycled material in R_1 (Figure 5a), contents of around 67 and 74 wt%, were obtained for recycle ratios of 20 and 40 wt%, respectively. These results indicate that much improved reaction conversions may be obtained through the use of reactor recycle. The percentage of TG, shown in Figures 5 (a and b), decreases with increasing the recycle ratio and also for the second recycle step (R_2) thus, affecting the simultaneous formation and consumption of DG and MG and formation of glycerol as a reaction by-product. For the condition that led to the highest conversion into esters (40 wt% recycle ratio - R_2) there was almost complete conversion of TG (0.7 wt%), low percentage of non-reacted intermediate compounds (11.8 wt%) and glycerol percentage of approximately 6.9 wt%. In both conditions studied low percentage of decomposition was observed (< 5.0wt%).

Analysis of glycerol formed in R_2 with the recycle ratio of 40 wt% revealed the existence of only 1 wt% of FAEE, the absence of TG, DG and MG and 5 wt% of water content and ~ 90 wt% of glycerol (analyzed using the method of Cocks and Van Rede (COCKS; VAN REDE, 1966)). Thus, the recycle reactor scheme may afford glycerol with relatively high purity, which may not be obtained through the conventional alkali-catalyzed method; this fact of course should be

taken into account for the purpose of implementation of a cost-effective transesterification process.

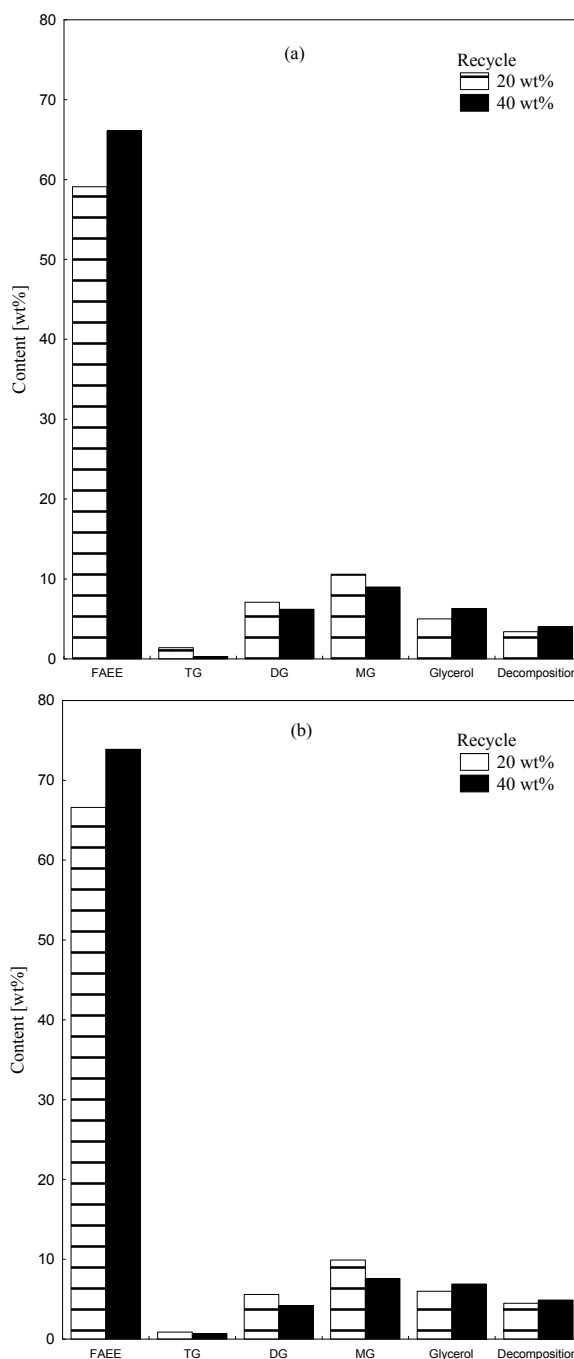

Figure 5. Effect of recycle ratio on the content of FAEE and TG, DG, MG, glycerol and decomposition at 598 K, 20 MPa, oil-to-ethanol mass ratio of 1:1 and residence time of 30 min. for a 20% recycle ratio and 40% recycle ratio for (a) R_1 (b) R_2 .

Conclusion

This work reported experimental data on FAEE production in a continuous tubular reactor,

evaluating two configurations of reactors, reactor in series and recycle reactor. Results showed that FAEE yield increases significantly in relation to the one-step reaction process, with low decomposition values. In the experimental conditions investigated, it reached 74 wt% FAEE content for the process operated with two reactors in series and about 75 wt% for the recycle configuration both at 20 MPa, 598 K, oil-to-ethanol mass ratio of 1:1 and 30 minutes of residence time, with a good purity degree obtained for glycerol.

Acknowledgements

The authors thank CNPq, Intecnial S.A., State University of Maringá (UEM) and URI/Campus de Erechim.

References

- AIMARETTI, N.; MANUALE, D. I.; MAZZIERI, V. M.; VERA, C. R.; YORI, C. Batch study of glycerol decomposition in one-stage supercritical production of biodiesel. **Energy and Fuel**, v. 23, n. 2, p. 1076-1080, 2009.
- ANITESCU, G.; DESHPANDE, A.; TAVLARIDES, L. L. Integrated technology for supercritical biodiesel production and power cogeneration. **Energy and Fuel**, v. 22, n. 2, p. 1391-1399, 2008.
- AOCS Ce 2-66. **Official methods and recommended practices of the american oil chemists' society**. 4th ed. Champaign: R.E. Walker, American Oil Chemists' Society, 1990.
- BERTOLDI, C.; SILVA, C.; BERNARDON, J. P.; CORAZZA, M. L.; CARDOZO FILHO, L.; OLIVEIRA, J. V.; CORAZZA, F. C. Continuous production of biodiesel from soybean oil in supercritical ethanol and carbon dioxide as co-solvent. **Energy and Fuels**, v. 23, n. 10, p. 5165-5172, 2009.
- BUSTO, M.; D'IPPOLITO, S. A.; YORI, J. C.; ITURRIA, M. E.; PIECK, C. L.; GRAU, J. M.; VERA, C. R. Influence of the axial dispersion on the performance of tubular reactors during the noncatalytic supercritical transesterification of triglycerides. **Energy and Fuels**, v. 20, n. 6, p. 2642-2647, 2006.
- CAO, W.; HAN, H.; ZHANG, J. Preparation of biodiesel from soybean oil using supercritical methanol and co-solvent. **Fuel**, v. 84, n. 4, p. 347-351, 2005.
- COCKS, L. V.; VAN REDE, C. **Laboratory handbook for oils and fats analysis**. London: Academic Press, 1966.
- CRAWFORD, J. W.; CRAWFORD, J. M.; CRAFTS, R. **Transesterification of oil to form biodiesel**, United States Patent, US 0232818 A1, 2007.
- DEMIRBAS, A. Biodiesel from vegetable oils via transesterification in supercritical methanol. **Energy: Conversion and Management**, v. 43, n. 17, p. 2349-2356, 2002.
- DEMIRBAS, A. Thermal degradation of fatty acids in biodiesel production by supercritical methanol. **Energy Exploration and Exploitation**, v. 25, n. 1, p. 63-70, 2007.
- D'IPPOLITO, S. A.; YORI, J. C.; ITURRIA, M. E.; PIECK, C. L.; VERA, C. R. Analysis of a two-step, non-catalytic, supercritical biodiesel production process with heat recovery. **Energy and Fuels**, v. 21, n. 1, p. 339-346, 2007.
- GRANADOS, M. L.; ALONSO, D. M.; ALBA-RUBIO, A. C.; MARISCAL, R.; OJEDA, M.; BRETTESS, P. Transesterification of triglycerides by CaO: Increase of the reaction rate by biodiesel addition. **Energy and Fuels**, v. 23, n. 4, p. 2259-2263, 2009.
- GUI, M. M.; LEE, K. T.; BHATIA, S. Supercritical ethanol technology for the production of biodiesel: process optimization studies. **Journal of Supercritical Fluids**, v. 49, n. 2, p. 286-292, 2009.
- HAN, H.; CAO, W.; ZHANG, J. Preparation of biodiesel from soybean oil using supercritical methanol and CO₂ as co-solvent. **Process Biochemistry**, v. 40, n. 9, p. 3148-3151, 2005.
- HE, H.; TAO, W.; ZHU, S. Continuous production of biodiesel from vegetable oil using supercritical methanol process. **Fuel**, v. 86, n. 3, p. 442-447, 2007.
- IMAHARA, H.; MINAMI, E.; HARI, S.; SAKA, S. Thermal stability of biodiesel in supercritical methanol. **Fuel**, v. 87, n. 1, p. 1-6, 2008.
- KASIM, N. S.; TSAI, T.; GUNAWAN, S.; JU, Y. Biodiesel production from rice bran oil and supercritical methanol. **Bioresource Technology**, v. 100, n. 8, p. 2399-2403, 2009.
- KUSDIANA, D.; SAKA, S. Biodiesel fuel from rapeseed oil as prepared in supercritical methanol. **Fuel**, v. 80, n. 2, p. 225-231, 2001.
- KUSDIANA, D.; SAKA, S. Effects of water on biodiesel fuel production by supercritical methanol treatment. **Bioresource Technology**, v. 91, n. 3, p. 289-295, 2004a.
- KUSDIANA, D.; SAKA, S. Two-step preparation for catalyst-free biodiesel fuel production. **Biotechnology and Applied Biochemistry**, v. 115, n. 1-3, p. 781-791, 2004b.
- MADRAS, G.; KOLLURU, C.; KUMAR, R. Synthesis of biodiesel in supercritical fluids. **Fuel**, v. 83, n. 14-15, p. 2029-2033, 2004.
- MINAMI, E.; SAKA, S. Kinetics of hydrolysis and methyl esterification for biodiesel production in two-step supercritical methanol process. **Fuel**, v. 85, n. 17-18, p. 2479-2483, 2006.
- PINNARAT, T.; SAVAGE, P. Assessment of noncatalytic biodiesel synthesis using supercritical reaction conditions. **Industrial and Engineering Chemistry Research**, v. 47, n. 18, p. 6801-6808, 2008.
- RATHORE, V.; MADRAS, G. Synthesis of biodiesel from edible and non-edible oils in supercritical alcohols and enzymatic synthesis in supercritical carbon dioxide. **Fuel**, v. 86, n. 17-18, p. 2650-2659, 2007.
- SILVA, C.; WESCHENFELDER, T. A.; ROVANI, S.; CORAZZA, F. C.; CORAZZA, M. L.; DARIVA, C.;

- OLIVEIRA, J. V. Continuous production of fatty acid ethyl esters from soybean oil in compressed ethanol. **Industrial and Engineering Chemistry Research**, v. 46, n. 16, p. 5304-5309, 2007.
- SILVA, C.; CASTILHOS, F.; OLIVEIRA, J. V.; FILHO, L. C. Continuous production of soybean biodiesel with compressed ethanol in a microtube reactor. **Fuel Process Technology**, v. 91, n. 10, p. 1274-1281, 2010.
- STANDARD UNE-EN 14103. **Determination of ester and linolenic acid methyl ester contents**. Madrid: Asociación Española de Normalización y Certificación, 2003.
- STANDARD UNE-EN 14105. **Determination of free and total glycerol and mono-, di-, triglyceride contents**. Madrid: Asociación Española de Normalización y Certificación, 2003.
- TAN, K. T.; LEE, K. T.; MOHAMED, A. R. Production of FAME by palm oil transesterification via supercritical methanol technology. **Biomass and Bioenergy**, v. 33, n. 8, p. 1096-1099, 2009.
- VIEITEZ, I.; SILVA, C.; BORGES, G. R.; CORAZZA, F. C.; OLIVEIRA, J. V.; GROMPONE, M. A.; JACHMANIÁN, I. Continuous production of soybean biodiesel in supercritical ethanol-water mixtures. **Energy and Fuels**, v. 22, n. 4, p. 2805-2809, 2008.
- VIEITEZ, I.; SILVA, C.; ALKIMIM, I.; BORGES, G. R.; CORAZZA, F. C.; OLIVEIRA, J. V.; GROMPONE, M. A.; JACHMANIÁN, I. Effect of temperature on the continuous synthesis of soybean esters under supercritical ethanol. **Energy and Fuels**, v. 23, n. 1, p. 558-563, 2009.
- WANG, C.; ZHOU, J.; CHEN, W.; WANG, W.; WU, Y.; ZHANG, J.; CHI, R.; YING, W. Effect of weak acids as a catalyst on the transesterification of soybean oil in supercritical methanol. **Energy Fuels**, v. 22, n. 5, p. 3479-3483, 2008.
- WEN, D.; JIANG, H.; ZHANG, K. Supercritical fluids technology for clean biofuel production. **Progress in Natural Science**, v. 19, n. 3, p. 273-284, 2009.

Received on September 30, 2010.

Accepted on May 26, 2011.

License information: This is an open-access article distributed under the terms of the Creative Commons Attribution License, which permits unrestricted use, distribution, and reproduction in any medium, provided the original work is properly cited.